

NAVARRO COUNTY COMMISSIONER'S COURT

A Special meeting of the Navarro County Commissioner's Court was held on Wednesday, the 12th day of November, 2014 at 10:00 a.m., in the Courtroom of the Navarro County Annex Building in Corsicana, Texas. Presiding HM Davenport, Commissioners present Jason Grant, Dick Martin, David Warren, and James Olsen.

1. 10:03 A.M. Motion to convene by Comm. Olsen sec by Comm. Warren
Carried unanimously
2. Opening prayer by Commissioner Martin
3. Pledge of Allegiance
4. Motion to approve canvassing of ballots for the November 4th, 2014 General Election by Comm. Olsen sec by Comm. Martin **TO WIT PG 1466-1473**
Carried unanimously
5. Motion to approve Ordering Stock law by Judge Davenport sec by Comm. Martin
Carried unanimously **TO WIT PG 1474-1475**
6. Motion to approve change order proposal from Phoenix 1 regarding the Fire Suppression system for the Courthouse contingent upon clarification of plumbing, city charges, removal of trees and hydrant cost by Judge Davenport sec by Comm. Warren
Carried unanimously **TO WIT PG 1476-1495**
7. Motion to adjourn by Comm. Martin sec by Comm. Warren
Carried unanimously

I, SHERRY DOWD, NAVARRO COUNTY CLERK, ATTEST THAT THE FOREGOING IS A TRUE AND ACCURATE ACCOUNTING OF THE COMMISSIONERS COURT'S AUTHORIZED PROCEEDING FOR NOVEMBER 12TH, 2014.

SIGNED 12TH DAY OF NOVEMBER, 2014.

SHERRY DOWD, COUNTY CLERK

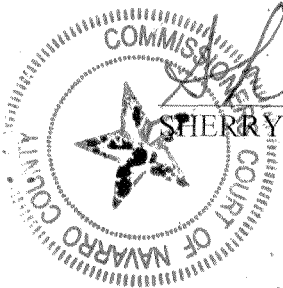
The seal of the Navarro County Commissioner's Court is circular. It features a five-pointed star in the center. The words "COMMISSIONER'S COURT OF NAVARRO COUNTY" are written around the perimeter of the seal.

#4

1466



CANVASS OF ELECTION

I, H. M. DAVENPORT, JR, COUNTY JUDGE OF NAVARRO COUNTY, TEXAS MET WITH THE COMMISSIONERS COURT SITTING AS THE CANVASSING BOARD TO CANVASS THE ELECTION HELD ON NOVEMBER 4, 2014 IN NAVARRO COUNTY, TEXAS.

I HEREBY CERTIFY THAT THE FIGURES ON THE RETURNS HAVE BEEN RECEIVED FROM THE NAVARRO COUNTY ELECTIONS ADMINISTRATOR AND APPROVED BY THE COMMISSIONERS COURT.

WITNESS MY HAND ON THIS THE 12TH DAY OF NOVEMBER 2014.

**H. M. DAVENPORT, JR
COUNTY JUDGE
NAVARRO COUNTY, TX**

1467

SUMMARY REPT-GROUP DETAIL

Navarro County, Texas
General and Special Election
November 4, 2014

UNOFFICIAL RESULTS

Run Date:11/12/14 08:16 AM

Report EL45A Page 001

	TOTAL VOTES	%	EV	EV MAIL	ED IVO	PROVISIONAL
PRECINCTS COUNTED (OF 30)	30	100.00				
REGISTERED VOTERS - TOTAL	27,341					
BALLOTS CAST - TOTAL	9,681		3,658	742	5,280	1
VOTER TURNOUT - TOTAL		35.41				

Straight Party

VOTE FOR 1

(WITH 30 OF 30 PRECINCTS COUNTED)

REPUBLICAN PARTY (REP)	4,213	73.68	1,598	386	2,229	0
DEMOCRATIC PARTY (DEM)	1,447	25.31	404	151	892	0
LIBERTARIAN PARTY (LIB)	48	.84	11	1	36	0
GREEN PARTY (GRN)	10	.17	3	0	7	0
Total	5,718		2,016	538	3,164	0
Over Votes	0		0	0	0	0
Under Votes	3,962		1,642	204	2,116	0

US Senator

VOTE FOR 1

(WITH 30 OF 30 PRECINCTS COUNTED)

John Cornyn (REP)	7,129	76.00	2,850	525	3,753	1
David M. Alameel (DEM)	1,960	20.90	606	192	1,162	0
Rebecca Paddock (LIB)	214	2.28	75	6	133	0
Emily "Spicybrown" Sanchez (GRN)	73	.78	21	6	46	0
WRITE-IN	4	.04	0	0	4	0
Total	9,380		3,552	729	5,098	1
Over Votes	0		0	0	0	0
Under Votes	301		106	13	182	0

US Representative, DIST 6

VOTE FOR 1

(WITH 30 OF 30 PRECINCTS COUNTED)

Joe Barton (REP)	7,266	76.74	2,864	526	3,875	1
David E. Cozad (DEM)	1,992	21.04	621	194	1,177	0
Hugh Chauvin (LIB)	210	2.22	81	8	121	0
Total	9,468		3,566	728	5,173	1
Over Votes	0		0	0	0	0
Under Votes	213		92	14	107	0

Governor

VOTE FOR 1

(WITH 30 OF 30 PRECINCTS COUNTED)

Greg Abbott (REP)	6,983	73.18	2,767	518	3,698	0
Wendy R. Davis (DEM)	2,376	24.90	768	212	1,396	0
Kathie Glass (LIB)	118	1.24	42	3	72	1
Brandon Parmer (GRN)	55	.58	16	4	35	0
WRITE-IN	10	.10	4	2	4	0
Total	9,542		3,597	739	5,205	1
Over Votes	0		0	0	0	0
Under Votes	139		61	3	75	0

	TOTAL VOTES	%	EV	EV MAIL	ED IVO	PROVISIONAL
Lieutenant Governor						
VOTE FOR 1						
(WITH 30 OF 30 PRECINCTS COUNTED)						
Dan Patrick (REP)	6,954	73.58	2,746	521	3,687	0
Leticia Van de Putte (DEM)	2,235	23.65	720	205	1,310	0
Robert D. Butler (LIB)	216	2.29	69	7	139	1
Chandrankantha Courtney (GRN)	46	.49	17	1	28	0
Total	9,451		3,552	734	5,164	1
Over Votes	0		0	0	0	0
Under Votes	230		106	8	116	0

Attorney General						
VOTE FOR 1						
(WITH 30 OF 30 PRECINCTS COUNTED)						
Ken Paxton (REP)	7,000	74.22	2,783	516	3,701	0
Sam Houston (DEM)	2,247	23.83	722	211	1,314	0
Jamie Balagia (LIB)	142	1.51	41	5	95	1
Jamar Osborne (GRN)	42	.45	15	1	26	0
Total	9,431		3,561	733	5,136	1
Over Votes	0		0	0	0	0
Under Votes	250		97	9	144	0

Comptroller of Public Accounts						
VOTE FOR 1						
(WITH 30 OF 30 PRECINCTS COUNTED)						
Glenn Hegar (REP)	6,826	72.90	2,704	501	3,621	0
Mike Collier (DEM)	2,253	24.06	730	219	1,304	0
Ben Sanders (LIB)	233	2.49	80	5	147	1
Deb Shafto (GRN)	52	.56	14	4	34	0
Total	9,364		3,528	729	5,106	1
Over Votes	0		0	0	0	0
Under Votes	317		130	13	174	0

Commissioner of the General Land Office						
VOTE FOR 1						
(WITH 30 OF 30 PRECINCTS COUNTED)						
George P. Bush (REP)	7,045	74.43	2,805	516	3,724	0
John Cook (DEM)	2,155	22.77	677	213	1,265	0
Justin Knight (LIB)	205	2.17	76	3	125	1
Valerie Alessi (GRN)	60	.63	16	2	42	0
Total	9,465		3,574	734	5,156	1
Over Votes	0		0	0	0	0
Under Votes	216		84	8	124	0

Commissioner of Agriculture						
VOTE FOR 1						
(WITH 30 OF 30 PRECINCTS COUNTED)						
Sid Miller (REP)	6,849	73.17	2,741	499	3,609	0
Jim Hogan (DEM)	2,244	23.97	689	219	1,336	0
David (Rocky) Palmquist (LIB)	173	1.85	55	4	113	1
Kenneth Kendrick (GRN)	94	1.00	37	6	51	0
Total	9,360		3,522	728	5,109	1
Over Votes	0		0	0	0	0
Under Votes	321		136	14	171	0

1467

	TOTAL VOTES	%	EV	EV MAIL	ED IVO	PROVISIONAL
Railroad Commissioner						
VOTE FOR 1						
(WITH 30 OF 30 PRECINCTS COUNTED)						
Ryan Sitton (REP)	6,793	72.78	2,709	497	3,587	0
Steve Brown (DEM)	2,186	23.42	684	216	1,285	1
Mark A. Miller (LIB)	252	2.70	90	9	153	0
Martina Salinas (GRN)	102	1.09	35	3	64	0
Total	9,333		3,518	725	5,089	1
Over Votes	0		0	0	0	0
Under Votes	348		140	17	191	0

Chief Justice, Supreme Court						
VOTE FOR 1						
(WITH 30 OF 30 PRECINCTS COUNTED)						
Nathan Hecht (REP)	6,869	73.73	2,749	498	3,621	1
William Moody (DEM)	2,217	23.80	681	220	1,316	0
Tom Oxford (LIB)	230	2.47	80	6	144	0
Total	9,316		3,510	724	5,081	1
Over Votes	0		0	0	0	0
Under Votes	365		148	18	199	0

Justice, Supreme Court, Place 6 Unexp						
VOTE FOR 1						
(WITH 30 OF 30 PRECINCTS COUNTED)						
Jeff Brown (REP)	6,904	74.32	2,747	495	3,662	0
Lawrence Edward Meyers (DEM)	2,149	23.13	672	215	1,262	0
Mark Ash (LIB)	236	2.54	77	11	147	1
Total	9,289		3,496	721	5,071	1
Over Votes	0		0	0	0	0
Under Votes	392		162	21	209	0

Justice, Supreme Court, P7						
VOTE FOR 1						
(WITH 30 OF 30 PRECINCTS COUNTED)						
Jeff Boyd (REP)	6,918	74.42	2,754	504	3,660	0
Gina Benavides (DEM)	2,108	22.68	664	206	1,237	1
Don Fulton (LIB)	217	2.33	70	10	137	0
Charles E. Waterbury (GRN)	53	.57	19	3	31	0
Total	9,296		3,507	723	5,065	1
Over Votes	0		0	0	0	0
Under Votes	385		151	19	215	0

Justice, Supreme Court, P8						
VOTE FOR 1						
(WITH 30 OF 30 PRECINCTS COUNTED)						
Phil Johnson (REP)	7,256	89.10	2,876	531	3,848	1
RS Roberto Koelsch (LIB)	551	6.77	191	31	329	0
Jim Chisolm (GRN)	337	4.14	130	13	194	0
Total	8,144		3,197	575	4,371	1
Over Votes	0		0	0	0	0
Under Votes	1,537		461	167	909	0

14710

	TOTAL VOTES	%	EV	EV MAIL	ED IVO	PROVISIONAL
Judge, CT of Criminal Appeals, P3						
VOTE FOR 1						
(WITH 30 OF 30 PRECINCTS COUNTED)						
Bert Richardson (REP)	6,861	73.96	2,744	494	3,623	0
John Granberg (DEM)	2,133	22.99	657	217	1,259	0
Mark W. Bennett (LIB)	283	3.05	91	11	180	1
Total	9,277		3,492	722	5,062	1
Over Votes	0		0	0	0	0
Under Votes	404		166	20	218	0

Judge, CT of Criminal Appeals, P4						
VOTE FOR 1						
(WITH 30 OF 30 PRECINCTS COUNTED)						
Kevin Patrick Yeary (REP)	7,103	87.05	2,806	521	3,776	0
Quanah Parker (LIB)	753	9.23	270	48	434	1
Judith Sanders-Castro (GRN)	304	3.73	117	11	176	0
Total	8,160		3,193	580	4,386	1
Over Votes	0		0	0	0	0
Under Votes	1,521		465	162	894	0

Judge, CT of Criminal Appeals, P9						
VOTE FOR 1						
(WITH 30 OF 30 PRECINCTS COUNTED)						
David Newell (REP)	7,259	88.26	2,876	524	3,859	0
William Bryan Strange, III (LIB)	707	8.60	242	38	426	1
George Joseph Altgelt (GRN)	259	3.15	95	11	153	0
Total	8,225		3,213	573	4,438	1
Over Votes	0		0	0	0	0
Under Votes	1,456		445	169	842	0

State Representative, District 8						
VOTE FOR 1						
(WITH 30 OF 30 PRECINCTS COUNTED)						
Byron Cook (REP)	7,287	85.95	2,849	549	3,888	1
John Wilford (LIB)	1,191	14.05	467	41	683	0
Total	8,478		3,316	590	4,571	1
Over Votes	0		0	0	0	0
Under Votes	1,203		342	152	709	0

Justice, 10th CT of Appeals Dist, P2						
VOTE FOR 1						
(WITH 30 OF 30 PRECINCTS COUNTED)						
Rex Davis (REP)	7,514	100.00	2,948	530	4,035	1
Total	7,514		2,948	530	4,035	1
Over Votes	0		0	0	0	0
Under Votes	2,167		710	212	1,245	0

Criminal Dist Attorney, Navarro County						
VOTE FOR 1						
(WITH 30 OF 30 PRECINCTS COUNTED)						
R. Lowell Thompson (REP)	7,821	100.00	3,085	550	4,185	1
Total	7,821		3,085	550	4,185	1
Over Votes	0		0	0	0	0
Under Votes	1,860		573	192	1,095	0

Run Date:11/12/14 08:16 AM

Report EL45A Page 005

TOTAL VOTES % EV EV MAIL ED IVO PROVISIONAL

County Judge

VOTE FOR 1

(WITH 30 OF 30 PRECINCTS COUNTED)

H.M. Davenport, Jr. (REP)	7,735	100.00	3,014	546	4,174	1
Total	7,735		3,014	546	4,174	1
Over Votes	0		0	0	0	0
Under Votes	1,946		644	196	1,106	0

District Clerk

VOTE FOR 1

(WITH 30 OF 30 PRECINCTS COUNTED)

Joshua B. Tackett (REP).	7,693	100.00	3,038	544	4,110	1
Total	7,693		3,038	544	4,110	1
Over Votes	0		0	0	0	0
Under Votes	1,988		620	198	1,170	0

County Clerk

VOTE FOR 1

(WITH 30 OF 30 PRECINCTS COUNTED)

Sherry Dowd (REP).	7,878	100.00	3,111	555	4,211	1
Total	7,878		3,111	555	4,211	1
Over Votes	0		0	0	0	0
Under Votes	1,803		547	187	1,069	0

County Treasurer

VOTE FOR 1

(WITH 30 OF 30 PRECINCTS COUNTED)

Ryan Thompson Douglas (REP)	7,720	100.00	3,052	540	4,127	1
Total	7,720		3,052	540	4,127	1
Over Votes	0		0	0	0	0
Under Votes	1,961		606	202	1,153	0

County Commissioner, PCT 2

VOTE FOR 1

(WITH 7 OF 7 PRECINCTS COUNTED)

R.E. "Dick" Martin, Jr. (REP).	1,459	100.00	478	107	874	0
Total	1,459		478	107	874	0
Over Votes	0		0	0	0	0
Under Votes	687		120	89	478	0

County Commissioner, PCT 4

VOTE FOR 1

(WITH 7 OF 7 PRECINCTS COUNTED)

James Olsen (REP).	2,572	100.00	1,083	190	1,298	1
Total	2,572		1,083	190	1,298	1
Over Votes	0		0	0	0	0
Under Votes	422		171	37	214	0

1472

Run Date:11/12/14 08:16 AM

Report EL45A Page 006

	TOTAL VOTES	%	EV	EV MAIL	ED IVO	PROVISIONAL
Justice of the Peace, PCT 1						
VOTE FOR 1						
(WITH 8 OF 8 PRECINCTS COUNTED)						
Vicki Gray (REP)	2,134	100.00	952	129	1,053	0
Total	2,134		952	129	1,053	0
Over Votes	0		0	0	0	0
Under Votes	445		180	31	234	0

Justice of the Peace, PCT 2						
VOTE FOR 1						
(WITH 7 OF 7 PRECINCTS COUNTED)						
Darrell Waller (REP)	1,481	100.00	488	107	886	0
Total	1,481		488	107	886	0
Over Votes	0		0	0	0	0
Under Votes	665		110	89	466	0

Justice of the Peace, PCT 3						
VOTE FOR 1						
(WITH 8 OF 8 PRECINCTS COUNTED)						
Jackie Freeland (REP)	1,607	100.00	544	131	932	0
Total	1,607		544	131	932	0
Over Votes	0		0	0	0	0
Under Votes	355		130	28	197	0

Justice of the Peace, PCT 4						
VOTE FOR 1						
(WITH 7 OF 7 PRECINCTS COUNTED)						
Connie Warren Hickman (REP)	2,521	100.00	1,067	185	1,268	1
Total	2,521		1,067	185	1,268	1
Over Votes	0		0	0	0	0
Under Votes	473		187	42	244	0

Proposed Constitutional Amendment						
VOTE FOR 1						
(WITH 30 OF 30 PRECINCTS COUNTED)						
FOR (A FAVOR)	6,637	78.76	2,709	466	3,461	1
AGAINST (EN CONTRA)	1,790	21.24	614	119	1,057	0
Total	8,427		3,323	585	4,518	1
Over Votes	0		0	0	0	0
Under Votes	1,254		335	157	762	0

Navarro County Proposition 1						
VOTE FOR 1						
(WITH 30 OF 30 PRECINCTS COUNTED)						
FOR	4,469	53.49	1,832	385	2,251	1
AGAINST	3,886	46.51	1,369	185	2,332	0
Total	8,355		3,201	570	4,583	1
Over Votes	0		0	0	0	0
Under Votes	1,326		457	172	697	0

1473

	TOTAL VOTES	%	EV	EV MAIL	ED IV0	PROVISIONAL
Navarro County Proposition 2						
VOTE FOR 1						
(WITH 30 OF 30 PRECINCTS COUNTED)						
FOR	2,512	27.76	855	72	1,585	0
AGAINST	6,536	72.24	2,621	569	3,345	1
Total	9,048		3,476	641	4,930	1
Over Votes	0		0	0	0	0
Under Votes	633		182	101	350	0

Kerens Proposition						
VOTE FOR 1						
(WITH 1 OF 1 PRECINCTS COUNTED)						
FOR	168	59.79	33	0	135	0
AGAINST	113	40.21	12	0	101	0
Total	281		45	0	236	0
Over Votes	0		0	0	0	0
Under Votes	9		0	0	9	0

Corsicana ISD						
VOTE FOR 1						
(WITH 22 OF 22 PRECINCTS COUNTED)						
FOR	2,598	53.06	1,426	195	977	0
AGAINST	2,298	46.94	1,126	202	970	0
Total	4,896		2,552	397	1,947	0
Over Votes	0		0	0	0	0
Under Votes	305		66	79	160	0

#5

1474

**ORDER DECLARING RESULT OF STOCK LAW
ELECTION**

THE STATE OF TEXAS

COUNTY OF NAVARRO

On this the 12th day of November, 2014, the Commissioners' Court of Navarro County, Texas, convened in a special session open to the public, at the regular meeting place thereof at the Navarro County Annex Building 1 in Navarro County, Texas, with the following members of the Court present, to wit:

H.M. Davenport, Jr	County Judge
Jason Grant,	Commissioner Precinct #1
Richard "Dick" Martin,	Commissioner Precinct #2
David "Butch" Warren,	Commissioner Precinct #3
James Olsen,	Commissioner Precinct #4

constituting a quorum, and among other proceedings, passed the following order:

"There came on to be considered the returns of an election held on the 4th day of November, 2014, in Navarro County, Texas, to determine whether or not to adopt the Stock Law specified in the Order calling said election.

It appearing to the satisfaction of the Court that said election was in all respects legally held, and that said returns were duly and legally made, and that there were cast at said election 8,354 valid and legal votes, of which number there were cast:

<u>4,468</u>	VOTES FOR	"ADOPTION OF THE STOCK LAW"
	<i>(VOTOS A FAVOR DE)</i>	

OR
(O)

<u>3,886</u>	VOTES AGAINST	"APROBACION DE LEY STOCK"
	<i>(VOTOS EN CONTRA DE)</i>	

IT IS THEREFORE, FOUND AND DECLARED AND SO ORDERED by the Commissioners Court of Navarro County, Texas:

That a majority of the qualified voters in Navarro County at said election voted to, Adopt the Stock Law as specified in the Order calling said election.

This Order shall be entered into record in the office of the Clerk of this Court, whereupon it shall be lawful in said above mentioned area to enforce the stock law as specified in the Order calling said election until such time as the qualified voters of said area may thereafter, at a legal election held for that purpose by a majority to decide otherwise.

It is further found and determined that written notice of the date, hour, place and subject of this meeting was posted on the bulletin board located at a place convenient and readily accessible to the general public at all times in the County Courthouse, Navarro County, Texas at least 72 hours preceding the scheduled time of this meeting and that all of the terms and provisions of Article 6252-17 Texas Revised Civil Statutes, have been complied with and a copy of said notice shall be attached to this Order and become a part thereof."

PASSED, APPROVED AND ADOPTED this the 12th day of November, 2014.

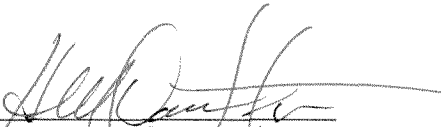

H. M. Davenport, Jr, County Judge
Navarro County, Texas



Jason Grant, Commissioner
Precinct #1

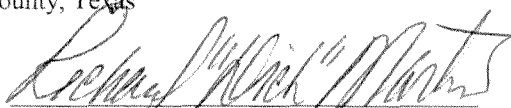

Richard "Dick" Martin, Commissioner
Precinct #2



David "Butch" Warren, Commissioner
Precinct #3



James Olsen,
Precinct #4



1476

Change Order Proposal

Architect:

1113 Architects, Inc.
1506 South Elm Street
Georgetown, TX 78626

Proposal Number: 023
Date of Issuance: 11-06-14
Date of Contract: 12-23-13
Architect Project No: NAV-1009
GC Project No.: 13-1352

FROM:

Phoenix I Restoration and Construction
14032 Distribution Way
Farmers Branch, TX 75234

Project: Navarro County Courthouse

Owner:

Navarro County
300 West 3rd Ave
Corsicana, TX 75110

This is not a change order or a directive to proceed with the work described in the proposed modifications.

DESCRIPTION:

Per the requirements of the City of Corsicana Fire Marshall the fire suppression system was modified to include fire sprinklers for the third floor, modification to the stand pipe system, installation of a fire line from the City water line to the building including the vault and FDC, and the install of a new fire hydrant along 12th Street.

Full Fire Suppression System (A-1)	\$ 111,752.00
Credit for original stand pipe scope (A-1)	(\$ 19,523.00)
2-Taps, 2-Fire lines, Fire Hydrant (City of Corsicana)	\$ 15,000.00
Insulating and heat tracing in the attic (PIRC Plumbing Division)	\$ 5,125.00
Marble Wainscot cut/repair @ 4 locations (Dee Brown)	\$ 2,535.00
2-Furr Outs (Neuco)	\$ 250.00
Demo of 2 trees (Instant Rain)	\$ 3,500.00
Replace Sod on Fire Line (Instant Rain)	\$ 810.00
Dedicated circuit in attic for heat trace (Madden Electric)	\$ 300.00
Wood Chair Rail/Wood Base (Hull)	\$ 0.00
Plaster Patching Labor: 8 hrs @ \$42.00/hr = \$336 x 8 locations (Phoenix I)	\$ 2,688.00
Plaster Patching Misc. Material: \$105/location x 8 locations (Phoenix I)	\$ 840.00
Painting Fire Sprinkler Pipes Labor: 20 hrs @ \$42.00/hr (Phoenix I)	\$ 840.00
Painting Fire Sprinkler Pipes Misc. Material (Phoenix I)	\$ 155.00

Phoenix I Restoration and Construction, Ltd.

14032 Distribution Way, Farmer's Branch, TX 75234 ● 214-902-0111 ● 214-904-9635 (Fax)

1477

Removal of Masonry for fire cabinets Labor: 22 hrs @ \$42/hr=\$924 x 8 locations (Phoenix I) \$ 7,392.00
Removal of Masonry for fire cabinets Misc. Material: \$135/location x 8 locations (Phoenix I) \$ 1,080.00

Subtotal: \$ 132,744.00
Phoenix I OH&P: \$ 19,911.60
Total Proposal Amount: \$ 152,655.60

Approved By 1113: Date:

 11-12-14

Approved By Navarro County: Date:

Phoenix I Restoration and Construction, Ltd.
14032 Distribution Way, Farmer's Branch, TX 75234 ● 214-902-0111 ● 214-904-9635 (Fax)

A-1 Fire & Safety Equipment Co.
 6701 Imperial
 Waco, Texas 76712
 Phone (254) 753-0337
 Fax (254) 752-0300

1478

PRICE QUOTATION

Quoted to: Phoenix 1 Restoration & Construction
 14032 Distribution Way
 Farmers Branch, Texas 75234

Date: 10/8/2014

Ship Date: 4 Weeks

Attn: Charlie Wilson
Phone: 214-902-0111
Cell:
Fax:
Email: cwilson@phoenix1.org

Terms: Draws/ Net Completion
Quoted By: Andy Restivo
Ship via: Our Truck

Price valid for: 25 Days

We are pleased to submit the following cost estimate:

Job Description: FIRE SPRINKLER SYSTEM

Page 1 of 2

MATERIALS

QUANTITY	DESCRIPTION	PRICE	TOTAL
	PROJECT		
	Navarro County Courthouse		
	3rd Floor		
1	Wet Pipe Fire Sprinkler System:		
	To Cover: 3rd Floor (65 x 160') Mechanical Area, Balcony East and West, and East Side Stand Pipe System (Excluded Area of Coverage above the Courtroom and Rotunda Area)		\$68,422.00
	Scope:		
	Starting Point: 1' AFF in Basement install Wet Pipe Fire Sprinkler and Stand Pipe System. Per NFPA 13		
	Price includes:		
	■ Wet Pipe	■ Drain Valves	
	■ Tamper & Pressure Switches	■ Spare Head Box	
	■ Bell	■ Piping	
	■ Floor Control Valve	■ Fittings	
	■ Class III Valve on Each Floor	■ Design	
	■ Sprinkler Heads	■ Labor to install	
	■ Hangers		
1	West Side Stand Pipe System		\$8,980.00
	Price Includes:		
	■ Piping	■ Core Drill Floors	
	■ Fitting	■ Tie into East Side Stand Pipe	
	■ Class III Valves in each Floor	■ Labor	
	■ Design		
8	Larsen Valve Cabinets:	\$433.00	\$4,464.00
	■ Stainless Steel		
	■ Semi Recessed		
	■ Fire Shield		
	■ Full Glass Door		
	Model FS VSS1818-RL Full Clear Acrylic #4 Finish		
Plus Applicable Tax If Required			
Total			

Thank you for letting us bid the above project for you.

Acceptance Signature: _____

Date Accepted: _____

Signed:  _____

1479

A-1 Fire & Safety Equipment Co.

6701 Imperial
Waco, Texas 76712
Phone (254) 753-0337
Fax (254) 752-0300

PRICE QUOTATION

Quoted to: Phoenix 1 Restoration & Construction
14032 Distribution Way
Farmers Branch, Texas 75234

Date: 10/08/2014
Revised: 11/3/2014
Ship Date: 4 Weeks

Attn: Charlie Wilson
Phone: 214-902-0111
Cell:
Fax:
Email: cwilson@phoenix1.org

Terms: Draws/ Net Completion
Quoted By: Andy Restivo
Ship via: Our Truck

Price valid for: 25 Days

We are pleased to submit the following cost estimate:

Job Description: FIRE SPRINKLER SYSTEM

Page 2 of 2

MATERIALS

QUANTITY	DESCRIPTION	PRICE	TOTAL
	PROJECT		
	Navarro County Courthouse		
	3rd Floor		
1	Underground Fire Service Line From Vault to 1' AFF		\$29,886.00
	Scope:		
	Starting After Tapping Valve, install Vault, with Backflow, Fire Department Connection and Piping to 1' AFF		
	Price includes:		
	■ C900 Piping	■ Free Standing FDC	
	■ Cast Elbows	■ Check Valve	
	■ Concrete Vault	■ Thrust Block	
	■ Backflow Device	■ Design	
	■ Testing	■ Labor To Install	
	Exclusions:		
	1) Heat for Attic		
	2) Fire Alarm		
	3) Fire Pump (if Required)		
	4) Saw Cutting & Patching Floor and Sidewalk for Water Supply Piping		
	5) City Tapping & Valve		
	5) Haul Off Spoils		
Plus Applicable Tax if Required			
Total			111,752

Thank you for letting us bid the above project for you.

Acceptance Signature: _____

Date Accepted: _____

Signed: _____



1480

Change Order Proposal

General Contractor:

Phoenix I Restoration & Construction, Ltd.
Attn: Charlie Wilson
14032 Distribution Way
Farmers Branch, TX 75234

Contractor

Other

Project: Navarro County Courthouse
300 West 3rd Avenue
Corsicana, TX 75110

Proposal Number: 001
Date of Issuance: 11-7-14
Date of Contract: 12-23-13

Owner: Navarro County Courthouse
300 West 3rd Avenue
Corsicana, TX 75110

Contractor Project No. 25-14-1352
Architect Project No. NAV-1009

This is not a change order or a directive to proceed with the work described in the proposed modifications.

DESCRIPTION:

Insulate Fire Sprinkler Piping in Attic Space

- | | |
|---|-------------------|
| 1. 1 – Chromalox RTAS Ambient Sensing
T-SAT #389589 | \$ 424.20 |
| 2. Chromalox SRF-5-IC- 5W/FT 120 volt
Approx. 200FT @\$5.71 per foot | \$1,142.00 |
| 3. Approx. 200FT of Fiberglass Insulation | \$ 714.30 |
| 4. Labor | |
| 1 – Plumber – 33 hours @ \$45.00/hr | \$1,485.00 |
| 1 – Plumber Helper – 30 hours @ \$35.00/hr | <u>\$1,050.00</u> |

Total Proposal Amount: \$4,815.50

Accepted: _____

REQUESTED BY: Bob Boynton
Phoenix I Restoration & Construction, Ltd. – Plumbing Division
bboynton@phoenixi.org

1481



STONE | MASONRY

**PROPOSAL
REPAIR & REMODEL**

Phoenix 1 Restoration & Construction
14032 Distribution Way
Farmers Branch, Texas 75234

November 4, 2014

ATTN: Charlie Wilson

PROJECT: Navarro County Courthouse
Corsicana, Texas

FOR THE SUM OF \$2535.00 (Two Thousand Five Hundred Thirty Five Dollars)

We propose to furnish the labor, material and equipment to cut the existing marble wainscot at four locations so that fire cabinets can be installed by others. Cutting or coring of wall substrate to be by others.

This bid does not include:

- | | |
|--|--|
| <input checked="" type="checkbox"/> Electrical Work | <input checked="" type="checkbox"/> Fire Cabinets |
| <input checked="" type="checkbox"/> Marble Replacement | <input checked="" type="checkbox"/> Mockup |
| <input checked="" type="checkbox"/> Premium Time Rates | <input checked="" type="checkbox"/> Repair & Remodel Tax |

Terms and Conditions:
The terms and conditions set forth on the reverse side are a part of this proposal.

ACCEPTED:

Sincerely,

DEE BROWN, INC.

DATE: _____

Robert G. Harris
Estimating/Marketing

xc: Bid File



DEE BROWN, INC.

Dallas, Texas

TERMS & CONDITIONS:

- (1) DBI shall not be responsible for cleaning or protection of materials, nor for replacement of breakage or damage unless such breakage or damage is caused directly by DBI or its employees.
- (2) Granite/natural stone is a natural material and variations from this color range can be expected.
- (3) Unless otherwise noted to the contrary, this proposal includes furnishing hoist, equipment, cleaning up our rubbish, scaffolding, taxes and insurance to comply with Federal and State laws.
- (4) This proposal includes no allowances for performance bond, electric power, watchman or other job pro-rata expenses.
- (5) Subcontracts will not be accepted for projects under \$25,000. Such projects need to be performed under Purchase Order or Work Order.
- (6) Minimum terms of payment: 100% of the value of the materials erected and materials delivered at the site to be paid within 30 days after our crew completes job.
- (7) This proposal is entirely withdrawn after twenty days unless we agree to an extension in writing.



1483

Neuco & Associates, Inc.

Drywall and Acoustical Contractors

2530 Glenda Lane, Suite 500 - Dallas, Texas 75229

Phone number - 972-620-2717

Fax number - 972-243-2701

WWW.NEUCOASSOC.COM

November 3, 2014

Charlie Wilson

Phoenix I

14032 Distribution Way

Farmers Branch, TX 75234

RE: Navarro County Courthouse

Subject: Additional Partitions at Fire Risers

Dear Ms. Wilson,

We propose to provide the following changes per our original scope of work and as described below:

- 1. Add approximately 4lf of drywall partition with gypsum board one side at Room 213 and 4lf of drywall partition with gypsum board one side at Room 315 to enclose fire risers..... Add \$ 250.00

Sincerely,

NEUCO AND ASSOCIATES, INC.

W. Tracy Patton

Estimator

1484

INSTANT RAIN DESIGNS, LLC

5311 Parkland Ave.
Dallas, Texas 75235

469 767 4565

Customer

Phoenix I
14032 Distribution Way
Farmers Branch, Texas 75234

Job Location:

Navarro County Courthouse
Corsicana, Tx

Sod Repair/Replacement

Sod replacement at fire line trench, including fine grading:
\$ 8.10 per sq. yd x 100 sq. yds.

\$ 810.00

(Additional sod if required to be at unit price of \$8.10 per sq. yd.)

Tree removal

1 tree

\$ 2,000.00 ea.

2 tree

\$ 1,500.00 ea.

These prices could be less depending on the actual size of the tree.
I have sent the photos to the tree removal man, but this was his guess
based on the previously removed trees.

Respectfully Submitted : Teri Slaughter

1485



MADDEN ELECTRIC SERVICES INC.

9870 N. Poetry Lane | Terrell, TX 75160 | Ph: 972.524.4449 | www.maddenelectricservicesinc.com

CHANGE ORDER:

DATE: 11/6/2014

PROJECT: NAVARRO COUNTY COURTHOUSE

DESCRIPTION: INSTALL DEDICATED CIRCUIT FOR HEAT TRACE

QTY	DESCRIPTION	COST	TOTAL
30	3/4 EMT	\$ 0.37	\$ 11.10
100	#12 THHN	\$ 0.22	\$ 22.00
2	3/4 CONN	\$ 0.64	\$ 1.28
5	3/4 COUPLING	\$ 0.70	\$ 3.50
4	3/4 STRAPS	\$ 0.50	\$ 2.00
1	20 AMP BREAKER	\$ 11.00	\$ 11.00
3	JOURNEYMAN	\$ 40.00	\$ 120.00
3	APPRENTICE	\$ 30.00	\$ 90.00
TOTAL			\$ 260.88
OVERHEAD	15%		\$ 39.12
TOTAL			\$ 300.00

FIRE-RATED CABINETS FLAME-SHIELD® OPTION

GENERAL DESCRIPTION: The **FLAME-SHIELD** option is available for a variety of Larsen's fire extinguisher, fire department valve, fire hose and fire blanket cabinets. It is designed specifically to maintain the integrity of one and two hour fire walls with all Larsen's recessed and semi-recessed cabinets. Warnock-Hersey has certified and listed Larsen's **FLAME-SHIELD** option for one and two hour combustible and non-combustible wall systems to meet requirements of UBC Standard 43-6 (ASTM E-814). Larsen's **FLAME-SHIELD** option assures the specifier that life safety codes will be maintained and by eliminating the need to continue the fire wall within the rough opening, saves the installer considerable time and expense. Larsen's **FLAME-SHIELD** option is appropriate for either new construction or renovation projects.

BOX SPECIFICATION: All boxes for Larsen's fire protection cabinets with the **FLAME-SHIELD** option are constructed of cold-rolled steel with baked acrylic enamel finish. The space between the double walls is lined entirely with 5/8" thick fire barrier material.

DOOR AND TRIM SPECIFICATION:

All of Larsen's door styles are available with the **FLAME-SHIELD** option. Please refer to the following catalog pages for illustrations and descriptions of these door styles:

1. Architectural Series Door Styles
2. Medallion Series Door Styles
3. Gemini Series Door Styles
4. Cameo Series Door Styles
5. Occult Series Door Styles

All of Larsen's door and trim materials are available with the **FLAME-SHIELD** option:

1. **Steel:** One piece, cold-rolled with a standard finish of white baked acrylic enamel.
2. **Aluminum:** Extruded or fabricated construction with a standard clear satin anodized finish. A wide selection of optional color anodized finishes is available.
3. **Stainless Steel:** One piece, 304 stainless steel with a standard finish #4 brushed finish or optional #8 polished finish.
4. **Solid Brass or Solid Bronze:** One piece with a standard #4 satin or optional #8 polished finish. All doors and trims have a clear protective coating.

TO SPECIFY LARSEN'S FLAME-SHIELD OPTION:

1. **SELECT THE CABINET TYPE AND SERIES REQUIRED**
 - A. Fire Extinguisher Cabinets (Fire-Rated Cabinet, Architectural Series, Medallion Series, Gemini Series, Cameo Series, Occult Series, Detention Cabinets)
 - B. Fire Blanket Cabinets
2. **SELECT THE SPECIFIC CABINET REQUIRED FROM THE MODEL NUMBERS WITH THE "FS" PREFIX** (refer to the dimension charts on the Fire Extinguisher Cabinets pages)
3. **INDICATE THE SPECIFIC DOOR STYLE REQUIRED**
See door and trim specifications above.
4. **SELECT ANY OPTIONS**
 - a. Die-Cut Lettering, Vigilante Alarm, Fire Handle
 - b. Special Finishes (paint, color anodized aluminum, #8 stainless steel, brass or bronze)
5. **SPECIFY: "Provide fire-rated cabinet with Larsen's Flame-Shield option, certified and listed by Warnock-Hersey for one and two hour combustible and non-combustible wall systems to meet the requirements of UBC Standard 7-5 (ASTM E-814-83). All fire-rated cabinets to have trims with reinforced corners and factory supplied anchoring devices."**

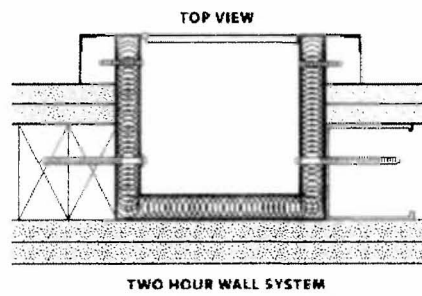
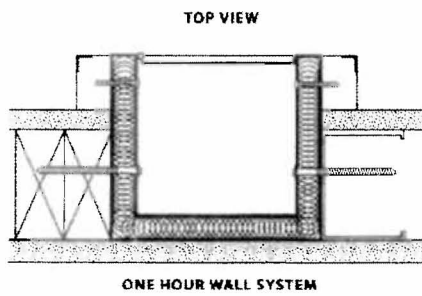
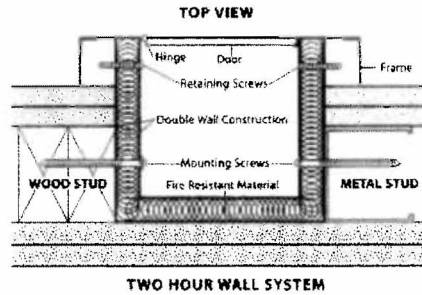
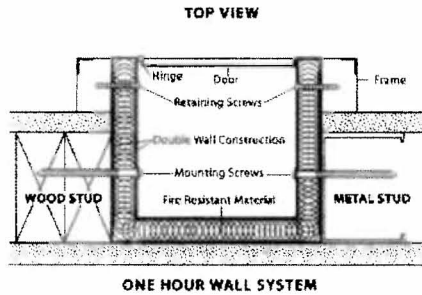

1487

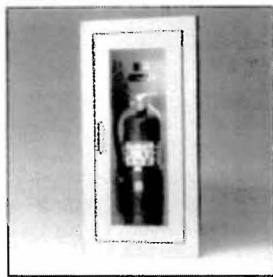

FS SS 2712-RK
Full Clear Acrylic Door

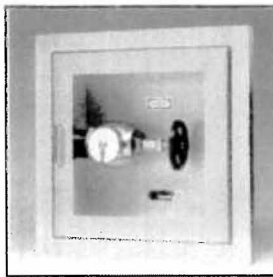

FS VCB 1818-RK
Full Clear Acrylic Door



FS HCS 3030-R
Full Clear Acrylic Door

WHY SHOULD YOU SPECIFY LARSEN'S FIRE-RATED CABINETS?

1. Larsen's does not subcontract the manufacturing of its fire-rated cabinets to outside sources, but rather maintains quality control by directing the entire fabrication process within its own production facilities.
2. Larsen's provides detailed installation instructions and factory supplied anchoring devices to insure a certified installation.
3. Larsen's is the only manufacturer who provides trims with welded corners.
4. Larsen's offers a wider selection of fire-rated cabinet sizes and types to include valve cabinets, fire hose cabinets, fire blanket cabinets, and heavy gauge cabinets for detention facilities (see **Larsen's Detention Equipment Catalog**).



Home Page	Fire Extinguishers & Cabinets	Fire Ext. & Cabinets Submittal & Detail Sheets	Access Panels	Access Panels Submittal & Detail Sheets	Detention Equipment	Marine, Industrial Fire Equipment	Aluminum Replacement Doors & Frames	Website Map
---------------------------	---	--	-------------------------------	---	-------------------------------------	---	---	-----------------------------

Contact Larsen's Mfg. - Request More Info

If you would like to contact us or to provide more information, please use the online form below. Please note we respect your privacy and will not distribute your information including email address to anyone else. Thank You!

Name:

E-mail:

Phone (optional):

How did you find us?
Please select one
Please select one

Request Info from Larsen's Manufacturing

Minnesota Division
1421 Commerce Lane SE, Minneapolis, MN 55432
Phone: (612) 512-1111 Toll Free: 1-800-527-1987
Fax: (612) 512-6900

Florida Division
1130 Alton 17th St., Ft. Lauderdale, FL 33311
Phone: (954) 456-1121 Toll Free: 1-800-262-1470
Fax: (954) 456-1150

FIRE HOSE AND VALVE CABINETS

1488

VC1818 and VC2626 SERIES

TO SPECIFY THE VC1818 and VC2626 SERIES:

1. Insert, after "VC," the appropriate prefix for the trim and door material (please refer HOW TO SPECIFY AND ORDER LARSEN'S FIRE HOSE AND VALVE CABINETS).
If STEEL - Use S.
If ALUMINUM - Use AL.
If STAINLESS STEEL - Use SS.
If BRASS - Use B. If BRONZE - Use BZ.
2. Select the required model number from the table below.
3. Select the door style from the illustrations on HOW TO SPECIFY AND ORDER LARSEN'S FIRE HOSE AND VALVE CABINETS.

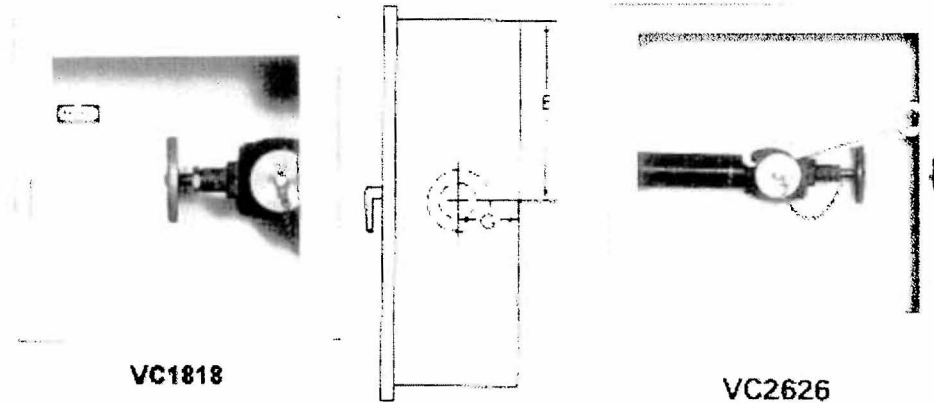

The VC2626 Series is designed specifically to meet fire codes which require the continuous revolution of a 12" long spanner wrench.

Model Number	Trim Style and Projection	Inside Box Dimensions H x W x D	Outside Trim Dimensions H x W***	Rough Opening H x W x D	Knockout Locations**		Interior Capacity
					E	G	
VC1818-R	Rec. 5/16	18 x 18 x 8	21½ x 21½	19 x 19 x 8¼	9"	4"	
FS VC1818-R	Rec. 5/16	18 x 18 x 8	21½ x 21½	20 ^{1/8} x 20 ^{1/8} x 9 ^{1/8}	--	--	One 2½"
VC1818-RK	Semi-Rec. 1¼	18 x 18 x 8	21½ x 21½	19 x 19 x 7¼	9"	4"	Fire Dept.
FS VC1818-RK	Semi-Rec. 1¼	18 x 18 x 8	21½ x 21½	20 ^{1/8} x 20 ^{1/8} x 8 ^{1/8}	--	--	valve
VC1818-RL	Semi-Rec. 2½	18 x 18 x 8	21½ x 21½	19 x 19 x 6	9"	4"	with
FS VC1818-RL	Semi-Rec. 2½	18 x 18 x 8	21½ x 21½	20 ^{1/8} x 20 ^{1/8} x 7	--	--	cap and
VC1818-RT	Trimless	18 x 18 x 8	--	--x --x8½†	9"	4"	chain
VC1818-SM	Surface Mtd.	21½ x 21½ x 8½	21½ x 21½	--	--	--	
VC2626-R	Rec. 5/16	26 x 26 x 8	29½ x 29½	27 x 27 x 8¼	13"	4"	
FS VC2626-R	Rec. 5/16	26 x 26 x 8	29½ x 29½	28 ^{1/8} x 28 ^{1/8} x 9 ^{1/8}	--	--	One 2½"
VC2626-RK	Semi-Rec. 1¼	26 x 26 x 8	29½ x 29½	27 x 27 x 7¼	13"	4"	Fire Dept.
FS VC2626-RK	Semi-Rec. 1¼	26 x 26 x 8	29½ x 29½	28 ^{1/8} x 28 ^{1/8} x 8 ^{1/8}	--	--	valve
VC2626-RL	Semi-Rec. 2½	26 x 26 x 8	29½ x 29½	27 x 27 x 6	13"	4"	with
FS VC2626-RL	Semi-Rec. 2½	26 x 26 x 8	29½ x 29½	28 ^{1/8} x 28 ^{1/8} x 7	--	--	cap and
VC2626-RT	Trimless	26 x 26 x 8	--	--x --x8½†	13"	4"	chain
VC2626-SM	Surface Mtd.	29½ x 29½ x 8½	29½ x 29½	--	--	--	

NOTE: "FS" models denote Larsen's "Flame-Shield" fire-rated cabinets. When specifying Larsen's "Flame-Shield" fire-rated cabinet option for the VC1818 and VC2626 Series, refer to the dimension chart above and select the models with an "FS" prefix. No knock-outs are provided with fire-rated cabinets.

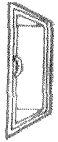

Larsen's® Valve Cabinets

Submittal and Detail Sheet

1489

PROJECT: _____
 MODEL NUMBER: _____
 ARCHITECT: _____
 DATE: _____

LOCATION: _____
 QUANTITY: _____
 CONTRACTOR: _____
 DISTRIBUTOR: _____

SPECIFICATIONS:

All recessed and semi-recessed cabinets and surface-mounted steel cabinets have a heavy gauge, white baked enamel box. Surface-mounted cabinets with aluminum door and trim have a box constructed entirely of clear or color anodized aluminum. Surface-mounted cabinets with stainless steel door and trim have a box constructed entirely of 304 stainless steel with a #4 finish.

Steel and stainless steel cabinets have a full 1/2" thick hollow metal heavy gauge door. Trims and doors feature one piece construction with satin finish turn handle, continuous matching hinge, and self-adjusting roller catch. Baked white enamel finish is standard for steel units. Stainless steel cabinets have a #4 finish, 304 stainless steel.

Aluminum cabinet doors and trims are extruded or fabricated aluminum with clear satin anodized finish. Aluminum door is 1/2" thick with satin finish matching pull handle and hinge. Color anodized finishes are available as options.

STEP 1: Select cabinet model number from the dimensions on the back of this sheet (or on attached sheet) and indicate on the top of this sheet. To specify aluminum trim and door, use the prefix, "AL" before the model number. To specify stainless steel trim and door, use the prefix, "SS" before the model number. **Note: Rough opening dimensions are larger for fire-rated cabinets. Please refer to separate Fire-Rated Cabinet Submittal and Detail Sheet.**

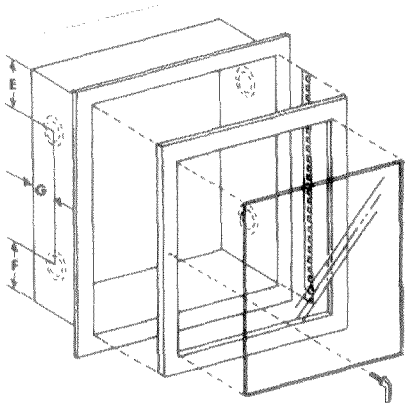

<input type="checkbox"/> Full Glass	<input type="checkbox"/> Horizontal Dub	<input type="checkbox"/> Vertical Dub
<input type="checkbox"/> Larsen-Loc®	<input type="checkbox"/> Solid	<input type="checkbox"/> Solid with Larsen-Loc®
<input type="checkbox"/> Gemma	<input type="checkbox"/> Camera	<input type="checkbox"/> Double Door

STEP 2: Select Door Style and Door Glazing (if applicable) below:

DOOR GLAZING:

- Clear Acrylic (Standard)
- Clear Tempered Safety Glass
- Clear Wire Glass
- Laminated Safety Glass
- Bronze Acrylic
- Gray Acrylic
- (Other) _____

* Note: Solid Door with Larsen-Loc® can be specified as Institutional Door (access only with key) by deleting the pull handle and decal.

VC1818 Larsen-Loc Door is full glass

<p>STEP 3: Indicate Trim and Door Material:</p> <ul style="list-style-type: none"> <input type="checkbox"/> Steel <input type="checkbox"/> Aluminum (AL) <input type="checkbox"/> Stainless (SS) <input type="checkbox"/> Other (specify) _____ 	<p>STEP 4: Indicate Trim Projection Below:</p> <div style="display: flex; justify-content: space-around;"> <div style="text-align: center;"> <input type="checkbox"/> 1/4" Flat Trim Fully Recessed </div> <div style="text-align: center;"> <input type="checkbox"/> 1 1/4" Square Trim Semi-Recessed </div> <div style="text-align: center;"> <input type="checkbox"/> 2 1/2" Rolled Edge Semi-Recessed* </div> <div style="text-align: center;"> <input type="checkbox"/> 1/4" Plaster Stop Trimless † </div> <div style="text-align: center;"> <input type="checkbox"/> Surface Mounted </div> </div>				
--	--	--	--	--	--

† Trimless cabinets must be installed before the drywall because their plaster stops must be behind the drywall. Trimless cabinets are not recommended for block wall installation.

LARSEN'S MANUFACTURING COMPANY - www.larsensmfg.com

7421 Commerce Lane N.E., Mpls, MN 55432 Phone: (763) 571-1181 FAX: (763) 571-6900

FLORIDA DIVISION: 3130 N.W. 17th Street, Ft. Lauderdale, FL 33311 Phone: (954) 486-3325 FAX: (954) 486-3352

©2011 Larsen's Mfg. Co.

1490

CABINET DIMENSIONS - VALVE CABINETS						
Model Number	Trim Style and Projection	Inside Box Dimensions* HxWxD	Outside Trim Dimensions HxW***	Rough Opening HxWxD	Knockout Locations** E G	Interior Capacity
VC 1818-R	Rec. 5/16	18 x 18 x 8	21½ x 21½	19 x 19 x 8¼	9" 4"	One 2½" Fire Dept. valve with cap And chain
VC 1818-RK	Semi-Rec. 1¼	18 x 18 x 8	21½ x 21½	19 x 19 x 7¼	9" 4"	
VC 1818-RL	Semi-Rec. 2½	18 x 18 x 8	21½ x 21½	19 x 19 x 6	9" 4"	
VC 1818-RT	Trimless	18 x 18 x 8	--	--x --x8½†	9" 4"	
VC 1818-SM	Surface Mtd.	21½ x 21½ x 8½	21½ x 21½	--	--	
Model Number	Trim Style and Projection	Inside Box Dimensions* HxWxD	Outside Trim Dimensions HxW***	Rough Opening HxWxD	Knockout Locations** E F G	Interior Capacity
VC 2430-R	Rec. 5/16	30 x 24 x 8	33½ x 27½	31 x 25 x 8¼	4" 4" 4"	Two Fire Dept. valves and a fire extinguisher or one hose rack unit with 75 ft. of rack hose
VC 2430-RK	Semi-Rec. 1¼	30 x 24 x 8	33½ x 27½	31 x 25 x 7¼	4" 4" 4"	
VC 2430-RL	Semi-Rec. 2½	30 x 24 x 8	33½ x 27½	31 x 25 x 6	4" 4" 4"	
VC 2430-RT	Trimless	30 x 24 x 8	--	--x --x8½†	4" 4" 4"	
VC 2430-SM	Surface Mtd.	33½ x 27½ x 8½	33½ x 27½	--	--	

Model Number	Trim Style and Projection	Inside Box Dimensions* HxWxD	Outside Trim Dimensions HxW***	Rough Opening HxWxD	Knockout Locations** E G	Interior Capacity
VC 2626-R	Rec. 5/16	26 x 26 x 8	29½ x 29½	27 x 27 x 8¼	13" 4"	One 2½" Fire Dept. valve with cap and chain
VC 2626-RK	Semi-Rec. 1¼	26 x 26 x 8	29½ x 29½	27 x 27 x 7¼	13" 4"	
VC 2626-RL	Semi-Rec. 2½	26 x 26 x 8	29½ x 29½	27 x 27 x 6	13" 4"	
VC 2626-RT	Trimless	26 x 26 x 8	--	--x --x 8½†	13" 4"	
VC 2626-SM	Surface Mtd.	29½ x 29½ x 8½	29½ x 29½	--	--	
Model Number	Trim Style and Projection	Inside Box Dimensions* HxWxD	Outside Trim Dimensions HxW***	Rough Opening HxWxD	Knockout Locations** F G	Interior Capacity
VC 4016-R	Rec. 5/16	40 x 16 x 8	43½ x 19½	41 x 17 x 8¼	6" 4"	One 2½" Fire Dept valve with cap and chain and a Fire Extinguisher
VC 4016-RK	Semi-Rec. 1¼	40 x 16 x 8	43½ x 19½	41 x 17 x 7¼	6" 4"	
VC 4016-RL	Semi-Rec. 2½	40 x 16 x 8	43½ x 19½	41 x 17 x 6	6" 4"	
VC 4016-RT	Trimless	40 x 16 x 8	--	--x --x 8½†	6" 4"	
VC 4016-SM	Surface Mtd.	43½ x 19½ x 8½	43½ x 19½	--	--	
Model Number	Trim Style and Projection	Inside Box Dimensions* HxWxD	Outside Trim Dimensions HxW	Rough Opening HxWxD	Knockout Locations** F G	Interior Capacity
VC 3616-R	Rec. 5/16	36x 16 x 8	39½ x 19½	37 x 17 x 8¼	6" 4"	One 2½" Fire Dept valve with cap and chain and one of the following Fire Ext. MP2½,MP5, DC2½, DC5,MP6,MP10,DC6, DC10, CD5
VC 3616-RK	Semi-Rec. 1¼	36x 16 x 8	39½ x 19½	37 x 17 x 7¼	6" 4"	
VC 3616-RL	Semi-Rec. 2½	36x 16 x 8	39½ x 19½	37 x 17 x 6	6" 4"	
VC 3616-RT	Trimless	36x 16 x 8	--	--x --x 8½†	6" 4"	
VC 3616-SM	Surface Mtd.	39½ x 19½ x 8½	39½ x 19½	--	--	

*FOR MODEL NUMBERS VC4016 and VC3616:

If the shelf is to be deleted with the valve installed at the top, insert the prefix "T" before "VC" and note the "E" knockout location of 6".

ROUGH OPENINGS ARE LARGER FOR FIRE-RATED CABINETS. PLEASE REFER TO FIRE-RATED CABINET SUBMITTAL AND DETAIL SHEET.

** No knockouts are provided for surface mounted cabinets unless specified. See knockout drawing on reverse side.

† Trimless cabinets must be installed before the drywall - plaster stop must be behind the drywall. Trimless are not recommended for block wall installation.

*** Deduct 3/4" from HxW Dimensions for Cabinets with Aluminum Door & Trim.

LARSEN'S MANUFACTURING COMPANY 7421 Commerce Lane N.E., Mpls, MN 55432
 www.larsensmfg.com Phone: (763) 571-1181 FAX: (763) 571-6900
 FLORIDA DIVISION: 3130 N.W. 17th Street, Ft. Lauderdale, FL 33311 Phone: (954) 486-3325 FAX: (954) 486-3352

©2011 Larsen's Mfg. Co.

BASEMENT PLAN

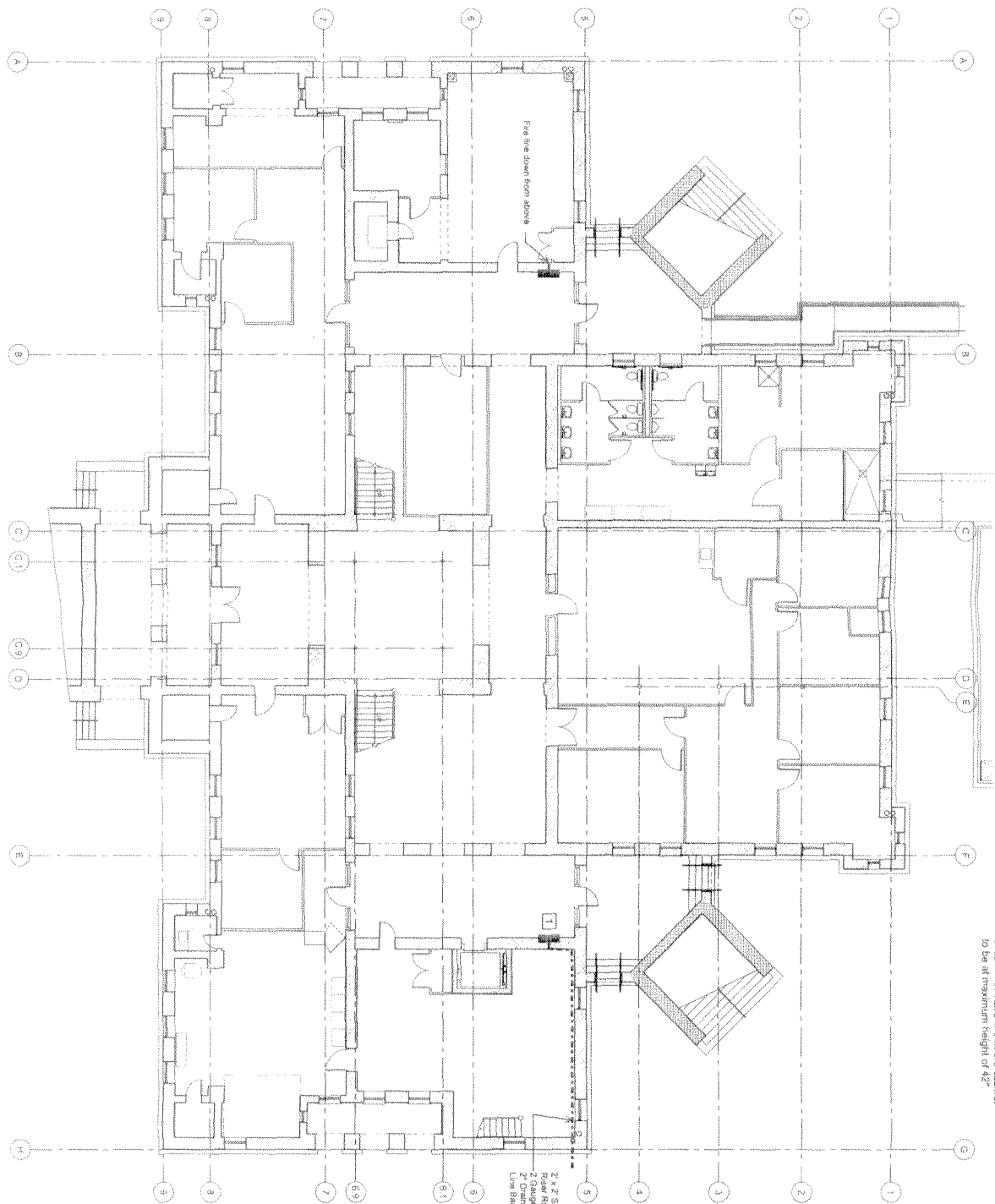

[1] Semi-Processed valve cabinet -
 Exact location to be determined.
 Location of valve within the cabinet
 to be at maximum height of 42"

2" x 2" Spokes Required
 2" Gauge
 2" Drain Valve with
 Line Back Out Wall
 Exterior
 Wall

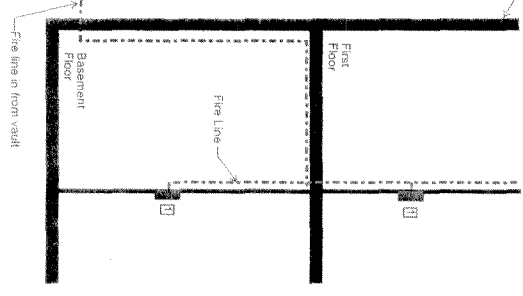

1ST FLOOR PLAN

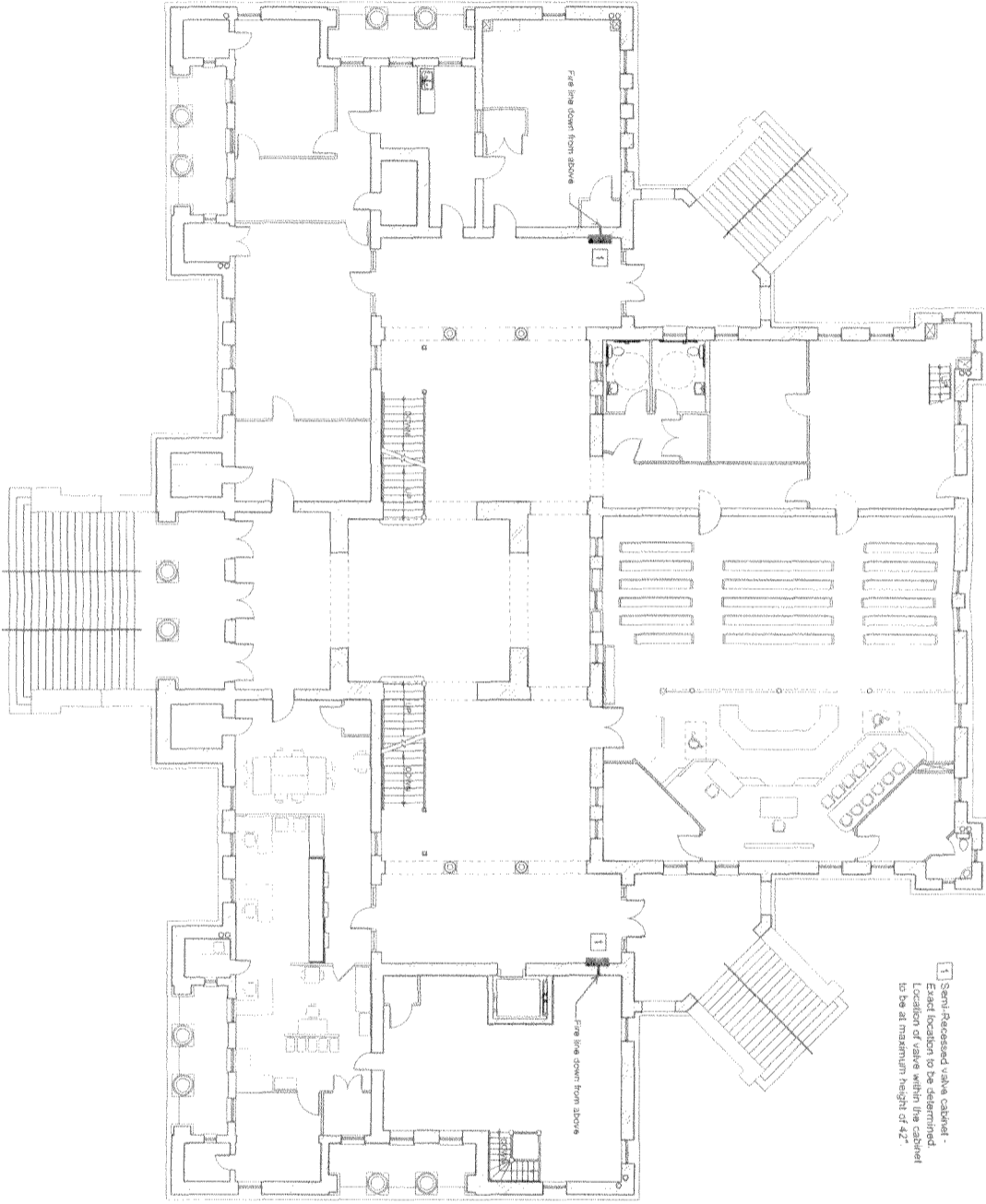

1 Semi-Recessed valve cabinet -
Exact location to be determined
Location of valve within the cabinet
to be at maximum height of 42"

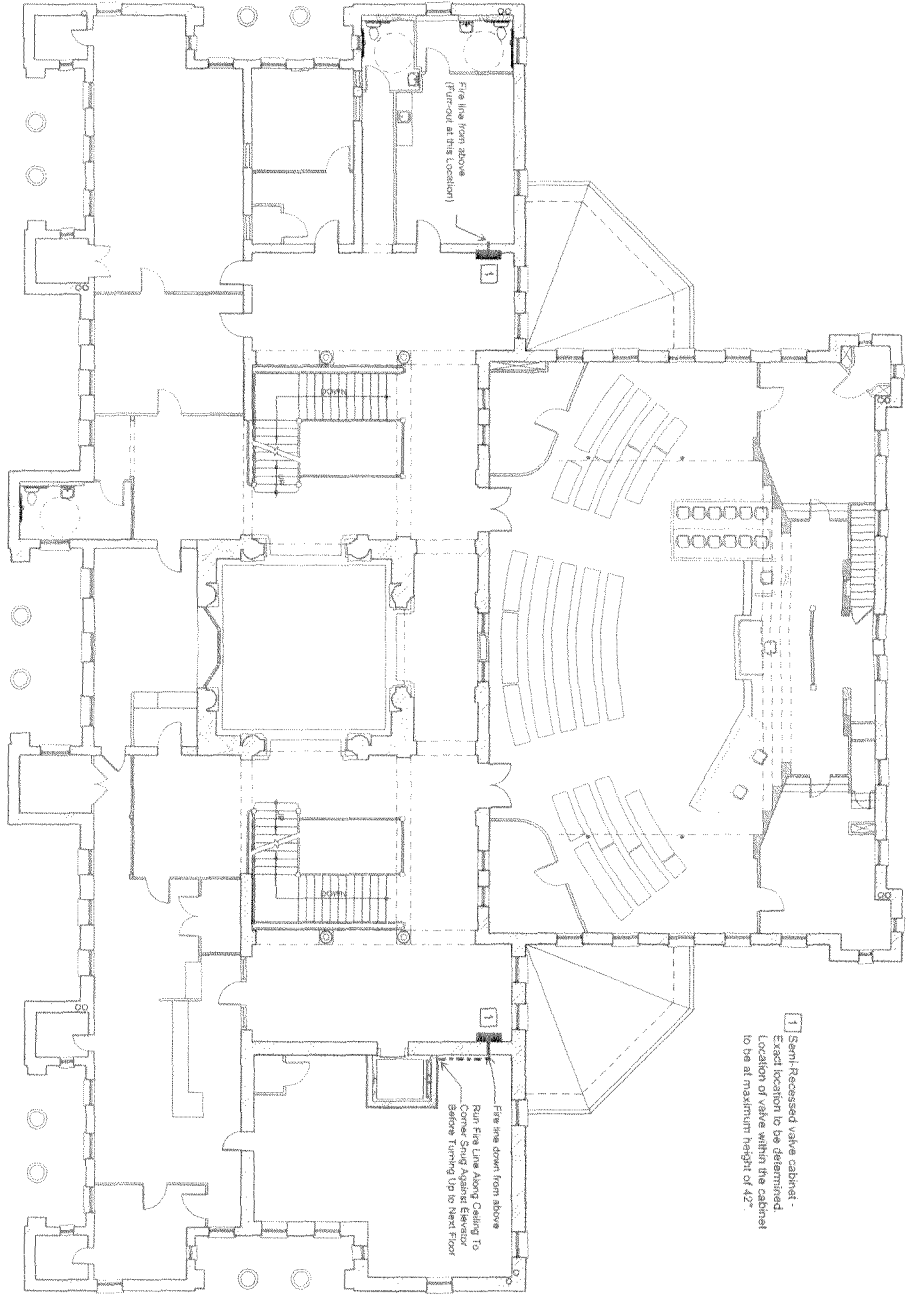

2ND FLOOR PLAN

3RD FLOOR PLAN

